

# KILEWS

KILEWS JAPAN CO., LTD.

- KTM - 10
- KTM - 100
- KTM - 50S

# 數位扭力計操作手冊

DIGITAL TORQUE METER INSTRUCTION MANUAL

OTW-Q01

## 操作前請閱讀全部說明

### 一. 安全警告 !!

1. 工作場所要保持乾淨。
  - ◎ 雜亂的工作區域及臺面容易造成傷害。
2. 注意工作場所的環境。
  - ◎ 勿將扭力計置放於雨中或潮濕處。
  - ◎ 請在正常室溫下(約 24°C)使用扭力計。
  - ◎ 工作場所應照明良好。
  - ◎ 勿于有易燃液體或氣體之處所使用扭力計。
3. 勿讓孩童接近。
  - ◎ 除操作人員以外應避免他人靠近工作場所。
4. 穿著適宜。
  - ◎ 勿穿著太寬鬆的衣物或珠寶，以免操作工具時勾扯拉到。
5. 謹慎操作。
  - ◎ 操作扭力計時應小心使用，注意操作方式及工作場所安全。
6. 穩固的固定機身主體。
  - ◎ 當測量較大扭力時應使用夾子或虎頭鉗等工具來固定起子，如此會比較安全，同時可用雙手操作起子。
7. 勿測試超過負荷量的扭力。
  - ◎ 若測試超過負荷量會使儀器損壞甚至產生意外或傷害。
8. 勿拆卸、撞擊或震動儀器。
  - ◎ 自行拆卸儀器或儀器遭過度撞擊、震動，可能導致儀器損壞。
9. 電擊警告!!
  - ◎ 勿以潮濕的手碰觸電源插座以免電擊。
10. 使用專用的充電器充電。
  - ◎ 使用非專用的充電器可能會損壞儀器，更可能引起火災意外。
11. 適當的充電。
  - ◎ 請依指示電壓充電。勿使用直流供電機或發電機充電，如此會產生高熱引發火災。
  - ◎ 充電時間不要超過 8 小時，過量充電會引起爆炸、過熱和電池漏液，引起火災。
12. 絕不可將電池(嵌裝於扭力計內)丟棄火中。
  - ◎ 如此會導致爆炸或釋放有毒物質。(丟棄電池的程式應依當地法律規定妥善處理或送到專門的回收處)
13. 如有下列情況應關閉電源。
  - ◎ 沒有使用時或進行充電時。
  - ◎ 進行修理時。
  - ◎ 其他可能招致危險的情況時。
14. 細心保養扭力計。
  - ◎ 請經常檢查彈簧座，不要使用變形或壞掉的接頭，以使操作正常安全。
  - ◎ 定期檢查電線和延長線，更換有損壞的線材。

15. 不可猛烈拉扯電線。
    - ◎ 不可搬運懸掛著電線的儀器，也不要拉扯電線來拔開插頭。
    - ◎ 不可將電線放在高溫、油膩和有銳利邊緣的物品旁。
  16. 檢查有無因零件損壞所造成的功能損失。
    - ◎ 在進一步使用儀器前，仔細檢查有無損壞、能否正常運作。
    - ◎ 檢查任何有可能會影響運作的零件是否正常。
  17. 請由專業的人員來修理儀器。
    - ◎ 勿改裝此產品。
    - ◎ 應在購買的經銷商處維修產品，若由非專業人員修理此產品，有可能會無法正常運作，甚至引起意外或傷害。
  18. 請使用專用的配件或附件。
    - ◎ 勿使用本操作手冊指示以外的配件或附件。
  19. 不使用時請小心儲放。
    - ◎ 扭力計應儲放在乾燥且兒童無法接觸之處、或是安全的地方。在運送時可利用此產品原有的包裝盒。
-

### 二. 外觀

- |                             |                                      |
|-----------------------------|--------------------------------------|
| (1) RESET SW (歸零開關)         | (7) DC IN (AC 充電孔)                   |
| (2) POWER SW (電源開關)         | (8) SOCKET (測試底座)                    |
| (3) LOBAT DISPLAY (低電量顯示)   | (9) KNOB (腳座固定螺絲)                    |
| (4) DISPLAY (液晶顯示器)         | (10) UNIT SW (單位切換開關)                |
| (5) DATA PUTPUT (資料輸出埠)     | (11) MODE SELECT SW (測量模式選擇開關)       |
| (6) ANALOG OUTPUT(類比式資料輸出埠) | (12) ZERO ADJUST (歸零調整器)【KTM-50S 限定】 |

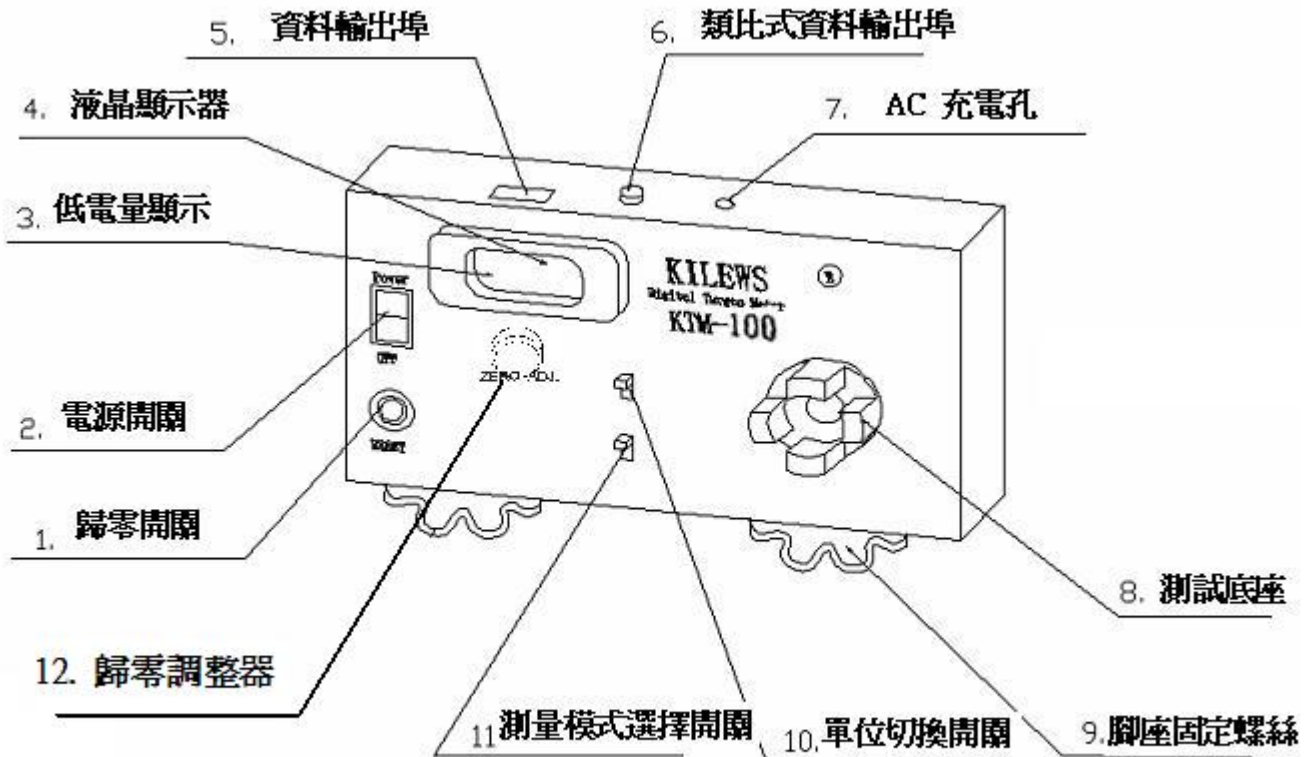

### SCREW JOINT

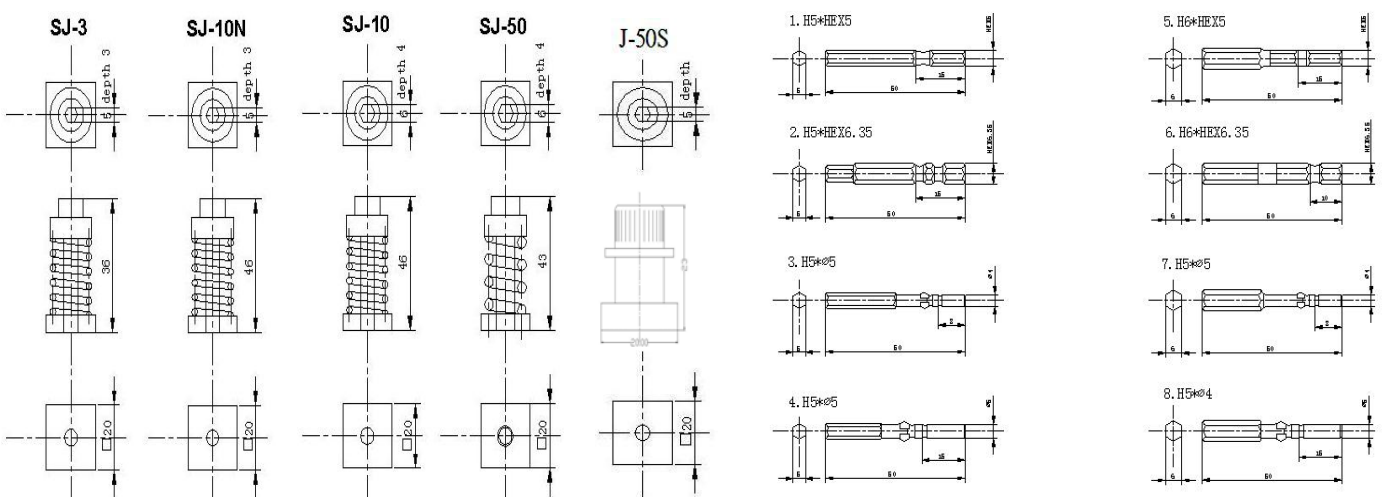

### 三. 規格

型 號	KTM-100	KTM-10	KTM-50S
測 量 範 圍	1.5 ~ 90.0 Lbf.in	0.15 ~9.0 Lbf.in	0.434 ~ 43.40Lbf.in
	1.5 ~ 100 Kgf.cm	0.15 ~ 10.0 Kgf.cm	0.5 ~ 50Kgf.cm
	0.15 ~ 10 N.m	0.015 ~ 1.0 N.m	0.049 ~ 4.90N.m
正 確 度	200 ~ 1000 數位顯示為±0.5% 15 ~ 199 數位顯示為±1%		
顯 示 器	三位元半 LCD 影像顯示		
測 試 方 向	正、反時鐘方向		
測量模式	P-P(Peak) 峰值模式	顯示負荷力最高值	
	TRACK 變值模式	顯示負荷力值的變化	
	P-D(Peak Down) 初值模式	顯示負荷力最初峰值	
數 據 輸 出	RS232 序列輸出 (速率 9600BPS)		
電 池 配 置	6VDC (Ni-Cd 1.2V x5 )		
使用扭力單位	Lbf.in 、Kgf.cm 、N.m		
充 電 時 間	少於 8 小時		
連續使用時間	約 12 小時		
電 池 壽 命	可充電 300 次以上，視操作情況而定		
專 用 充 電 器	輸入:AC 110V or 220V 輸出:DC 7.25V(120mA)		
底 座 尺 寸	20 方形 和 9.5 方形		
機 體 尺 寸	230(長)x123(寬)x65(高)		
重 量	約 1.5Kg		

### 四. 準備與測量方法

#### 4-1 安裝

- (1)測量儀器在測量較大扭力時可能會揮動起來。因此測量儀器必須用穩固的腳座器具來固定它。
- (2)KTM-50S 只能測試本公司產品半自動型號 例如：SK-205LS；SK-215LS；SK-2125LS；SK-2135LS；SK-2145LS  
SK-2205LS；SK-2215LS；SK-2225LS；SK-2235LS；SK-2245LS  
TKS-1300LS；TKS-1500LS；TKS-2500LS；TKS-3500LS；TKS-4500LS  
BSD-1000LS；BSD-1200LS
- (3)KTM-10；KTM-100 皆可以測試電動起子全自動型號的扭力；但是必需慎選測試彈簧座。

#### 4-2 測量模式的設定

有以下兩種模式可供選擇。(視使用用途來選擇)

- (1) P-P(Peak) 峰值模式：顯示測量到的最大扭力值。
- (2) TRACK 變值模式：顯示即時的扭力值。
- (3) P-D(Peak Down) 初值模式：顯示第一個峰值。

#### 4-3 測量方式

- (1) 歸零調整: 打開扭力計電源, 再將測量模式切換到” TRACK”, 此時顯示器的數值應為零。若不是零則按” 歸零開關” 將數值歸零(若為 KTM-50S 型號, 請直接旋轉” 歸零調整器” 即可), 接著將測量模式切換為” PEAK” 。
- (2) 準備好受測工具並銜接, 並開始測量扭力。
- (3) 測量時應順時針完全鎖緊或工具自行停止或跳脫為止。
- (4) 當測量完成後, 顯示器上的數值就是該次測量的扭力值。
- (5) 如果要再進行測量, 再次測量前按” 歸零開關” 將顯示器的資料清除。
- (6) 儀器在連續 10 分鐘未使用的情況下, 將會自動關機。
- (7) 若使用者需要測量扭力變化可切至 TRACK 變值模式

#### 五. 充電

當顯示器上出現” LOBAT” 字樣時表示扭力計電量不足, 需進行充電。

請關閉扭力計電源, 以隨機配備的充電器, 接妥正確電源與扭力計充電孔即可進行充電。

充電時間請勿超過 8 小時, 以免造成電池過熱、漏液甚至燃燒等傷害。

#### 六. 資料傳輸(只限 PEAK 模式)

資料傳輸(需搭配專用傳輸線與軟體): 在每次測量完畢按歸零開關時(或機器自動歸零時), 扭力計會自動將測得的資料經傳輸裝置輸出到電腦上。

※ 搭配用的傳輸裝置為選購產品; 扭力測試儀必須切於 PEAK 模式。

#### 七. 服務保證

本產品在購買後一年內若有因生產或運送過程瑕疵而產生的故障情況, 本公司無條件提供修理服務; 但下情況則被排除在外:

- ◎ 不當使用、修理或重組儀器而導致故障者。
- ◎ 在購買後因摔落等事故而導致故障者。
- ◎ 因天然災害、污染和不正常的電壓所導致的故障。

#### 八. 校正服務

本產品於出廠前皆已做過可靠且符合國際標準的準確度校正, 但為維持扭力計的精確度, 應將扭力計做定期的校驗。本公司另提供專業並符合標準的調修服務, 唯保證期間外的校驗服務得另收費用。

---

## 九. 電動起子與扭力計

### 1. 電動起子之扭力調整

- 旋轉扭力調整環以增加或減少扭力輸出。  
順時針方向調至較高刻度，代表增加扭力；逆時針方向調至較低刻度，代表減少扭力。
- 操作電動起子時應循序漸進，先操作小扭力試鎖螺絲，若感覺扭力不足再漸漸調高扭力。
- 電動起子的扭力輸出和扭力刻度的相互關係可參考說明書內的”扭力曲線圖”。  
鎖緊螺絲之扭力大小取決於螺絲本身之型式、材質尺寸及其鉚合物之材質。
- 當被鎖物件鎖附完成時，視其符合品質標準後，再用扭力計測量該電動起子的正確扭力，若鎖附狀況未達標準，則調整電動起子扭力，直到符合標準為止。
- 電動起子用扭力計測量並記錄好扭力後，將起子外殼前鎖環旋開，換上扭力固定環，如此可以防止異常的扭力變動。

### 2. 扭力計的使用方法（工具：扭力計、全自動電動起子）

- 根據螺絲鎖附所需要的扭力選擇適當的電動起子型號，  
可參考電動起子目錄或電動起子向量圖表
- 選擇合適的扭力計: KTM-10 最大可測扭力為 10Kgf-cm，KTM-100 可測最大扭力為 100 Kgf-cm，KTM-50S 可測最大扭力為 50Kgf.cm；選擇扭力計彈簧座（依欲測試的扭力為準可分為四種，請參考以下表格）。

使用範圍(Kgf-cm)	扭力計	彈簧座	備註
3.0 以下	KTM-10	SJ-3	最大可測 3Kgf-cm
3.0~10.0	KTM-10	SJ-10N	最大可測 10Kgf-cm
	KTM-100	SJ-10	
10.0~50.0	KTM-100	SJ-50	最大可測 50Kgf-cm
0.5~50.0	KTM-50S	J-50S	最大可測 50Kgf-cm 半自動起子專用

- 測試步驟：
  - ①打開電源開關。
  - ②測量模式（MODE）設定為“TRACK”。
  - ③單位切換開關設定為欲測試的單位（Lbf-in；Kgf-cm；N-m）。
- 歸零調整: 檢視顯示器數值是否為歸零狀態，若不是則按歸零開關（Reset），使顯示歸零。
- 測量模式(MODE)設定為“PEAK”。
- 電動起子套上接杆，另一端則置於彈簧座接頭端，啟動電動起子開始測量電動起子輸出扭力。
- 當數值顯示後即表示電動起子測量正常與完成；顯示器上的數值就是電動起子輸出扭力值。
- 完成電動起子測定後，需反轉放鬆彈簧座(J-50 除外)，以防止彈簧座彈性疲乏，按歸零開關清除螢幕後即可繼續測量。
- 使用同一把電動起子於不同廠牌型號的扭力計（或扭力計彈簧座）會產生不同的扭力值誤差，其誤差來源多為彈簧座的彈簧特性不同所致。同一工作場所有兩台以上的扭力計時，使用單位應定期校驗扭力計並比對其彈簧座的彈簧特性差異是否過大，若差異過大則應替換新的彈簧或整組彈簧座。
- 使用扭力計時請勿同時進行充電，以免影響測試資料的準確性。

如有任何疑問 請與當地代理商聯繫！

# Operation Menul for Digital Torque Meter

## Model: KTM-100 KTM-10 KTM-50S

### 1. Caution for safety

---

1. Keep work area always clean.  
Cluttered areas and benches may invite injuries.
  2. Consider work area environment.  
Do not use torque meter in the rain or in the damp or wet place.  
Use the product at a place left at constant temperature(about 24°C).  
Keep work place well lighted.  
Do not use or charge the product in presence of flammable liquids or gases.
  3. Keep children away.  
Keep any person other than the operator(s) away from work area.
  4. Dress properly.  
Do not wear loose clothing or jewelry, which may be caught in moving parts.
  5. Work with the most care.  
When using the product, carefully work, with consideration to how to handle, how to work, work environment, etc.
  6. Fix main body firmly.  
When operated for measuring a large torque, use clamps or a vise, etc. ,It is not only more safe than holding by hand but also makes it possible to grip the screwdriver by both hands.
  7. Do not apply a torque exceeding the permissible load.  
If applied beyond the permissible load, it may cause damage to the detector, resulting in accident or injury.
  8. Do not disassembly, shock and vibrate this product.  
Avoid disassembling the product that is a precise instrument. If the torque meter is damaged by excessive shock or vibration, the product may not only show the full performance but also result in accident or injury.
  9. Caution to electric shock  
Do not touch power plug by wet hand. It may cause electricshock.
  10. For charging the battery be sure to use only exclusive charger.  
Using a charger other than specified may cause a fire or injury.
  11. Charge properly.  
Charge on the indicated voltage. Do not use DC power or engine generator. It may cause abnormal heat, resulting in a fire.  
Keep the charging time not longer than 8 hours. Overcharge may bursting, overheat and liquid leakage, resulting in a fire or injury.  
Charge in a well-ventilated place. While being charged, do not cover with cloth.
  12. Never throw the battery(built-in the torque meter) into fire.  
It may cause burst or give off toxic substance. (The procedure for scrapping the battery shall be followed in accordance with local or regional law on waste disposal. If there is no local or regional law on waste disposal, be sure to dispose of the battery at a recycling shop.)
  13. In the following cases, turn off the main switch and disconnect the plug from outlet.  
When not used or charged;  
When repaired;  
When any other danger is expected.
  14. Maintain torque meter with care.  
For better and safer performance, check screw joints regularly and use ones whose tips are free from deformation and wear down.  
For replacement of accessories follow the instruction manual.  
Inspect cords and extension cords periodically and if damaged, replace them.
  15. Do not handle cord violently.  
Do not carry the product hanging by cord or draw out socket from outlet by pulling cord.  
Do not put cord near to a hot, oily or edgy part.
  16. Check for absence of damaged parts.  
Before further use of the product, carefully check for no damage, normal operation, or intended functions.  
Check whether or not any other components that may affect its operation are normal.  
Replace parts according to the instruction manual.
  17. Have the product repaired by the specialized dealer.  
Do not modify this product.  
Repair should be made always by the dealer where you purchased the product. If repaired by any person with no knowledge or skills of repair, it may not only show the full performance but also may cause any accident or injury.
-

18. Use only the specified accessories and attachments.

Do not use any accessories and attachments other than ones specified in this instruction manual.

19. Store properly when not in use.

Store the torque meter in a dry place and in a height out of children's reach, or secured area.

To transport the product, reuse the packing case with which this product was delivered.

---

### 2. Appearance

(1) Reset Switch	(7) AC Adaptor Terminal
(2) Power Switch	(8) Socket
(3) Lobat Display	(9) Knob
(4) Display	(10) Measuring Unit Switch
(5) Data Output Terminal	(11) Measuring Mode Select Switch
(6) Analog Output Terminal	(12) ZERO ADJUST 【SKM-50S ONLY】

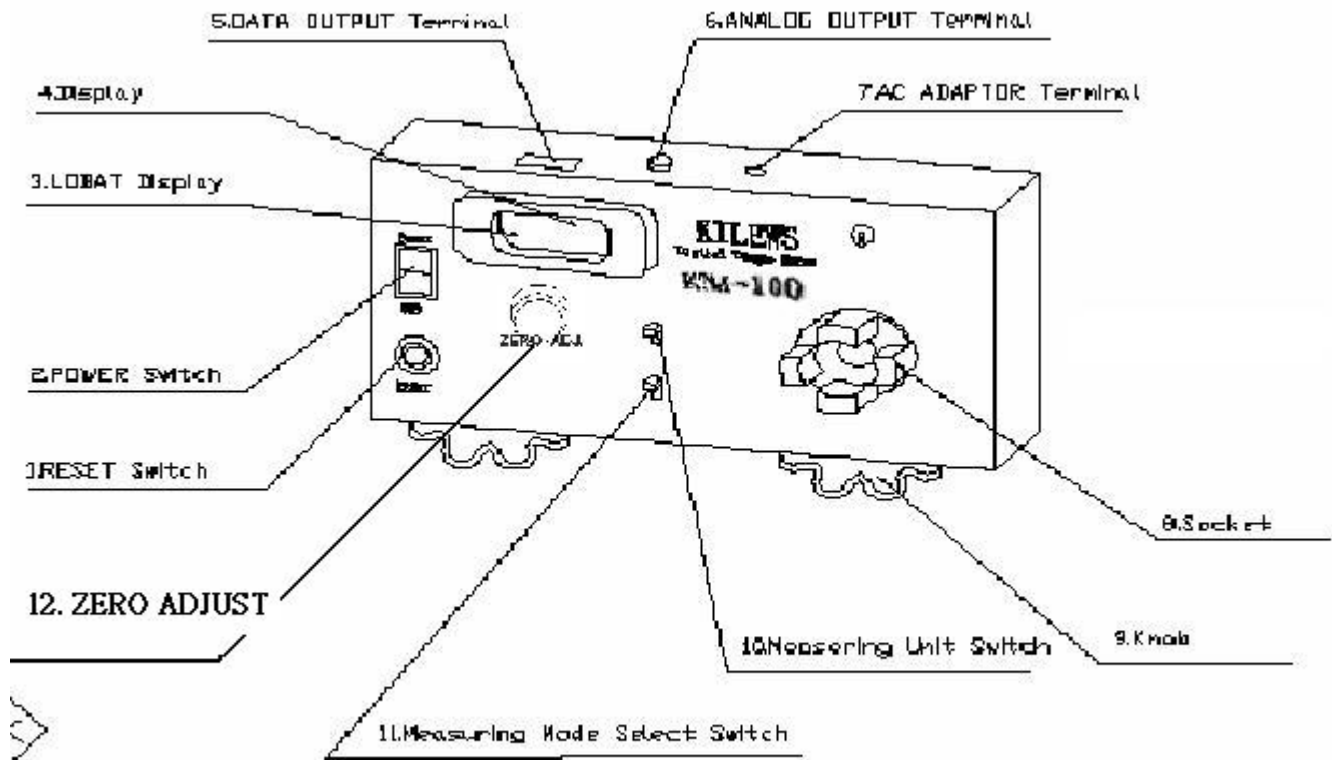

### SCREW JOINT

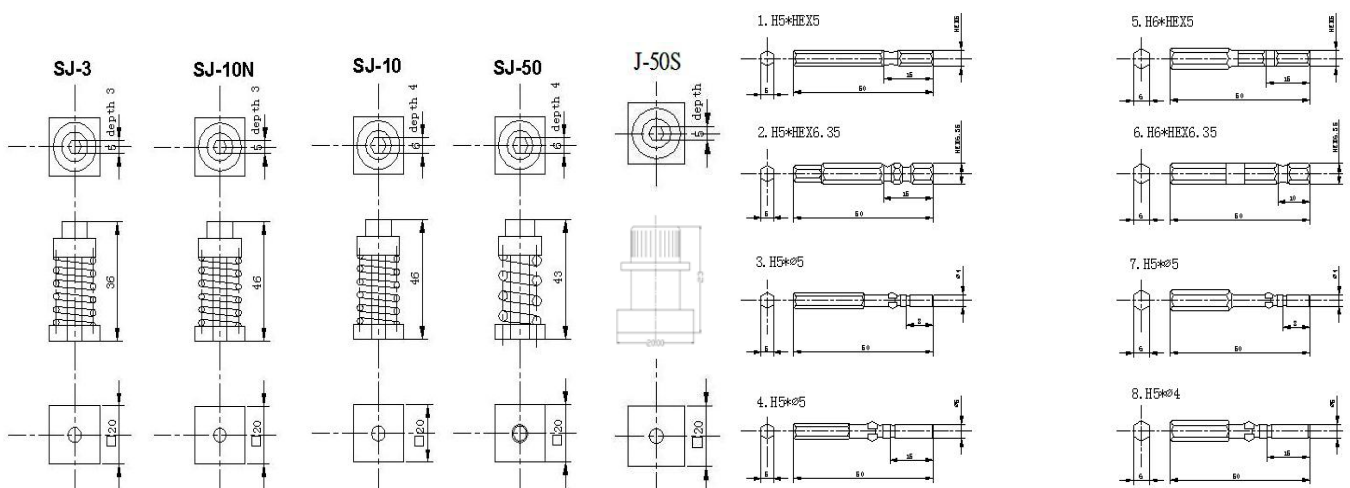

**3. Specifications**

MODEL		KTM-100	KTM-10	KTM-50S
Measuring range	lbf · in	1.5~90.0	0.15 ~9.0 Lbf.in	0.434 ~ 43.40Lbf.in
	kgf · cm	1.5~100.0	0.15 ~ 10.0 Kgf.cm	0.5 ~ 50Kgf.cm
	N·m	0.15~10.00	0.015 ~ 1.0 N.m	0.049 ~ 4.90N.m
Accuracy		From 200~1000 digit display within +/- 0.5% From 15~199 digit display within +/-1digit		
Display		3.5 figures of LCD		
Measuring direction		CW · CCW		
Measurement mode 3 way	P-P (peak)	Peak load value hold.		
	TRACK	Indication of real time torque value.		
	P-D (peak down)	Indication peak down point and hold.		
Data transfer		Serial interface RS232C (Baud rate : 9600)		
Power supply		6 VDC (Ni-Cd chargeable battery 1.2V×5cells )		
Measuring unit		lbf · in-kgf · cm-N·m (selectable)		
Charging time		From empty - 8hours		
Continuous working time		About 12hours		
Battery life		Chargeable for 300 times or more. However, it varies depending on operating conditions.		
Exclusive charger		INPUT : 120V or 230V 60Hz OUTPUT : DC7.25V 120mA		
Socket size		20mm square and 9.5mm square		
Size		230(W) × 123(D) × 65(H)		
Weight		About 1 kg		

**\*Do not use for measurement of impact tool. Do not apply more than the specified torque.**

**4. Preparation and the measuring method****4.1 Installation**

A measuring instrument may be brandished at the time of measurement of a large torque.

Surely, a measuring instrument should use a fixed knob etc. and fix it firmly.

**4.2 A setup in the measurement mode**

The 3 following modes can be chosen with the setting. (It unites with the use purpose and please choose.)

(1) PP (peak measurement) : The maximum under measurement is always displayed.

(2) TRACK (track measurement) : The value of the load torque concerning the detection machine is displayed as it is.

(3) PD (peakdown measurement) : Value when load torque value changes from a rise to descent is displayed.

Carry out after pushing a CLEAR button at once when applying re-load.

\*PD and PP measurement operates from 10 or more numerical values.

**4.3 Measuring method**

(1) Check that the display part is zero at the time of power supply ON. If display is not show as zero, set a measurement mode select switch to TRACK, push CLEAR button, and set it as back PP which performed zero adjustment.

(2) The bit of screwdriver to measure among the screw part of screw joint is set firmly, and screwdriver is started.

(3) It checks that operation of screwdriver has been completed normally, the measurement torque value of a display part is read, and it becomes a measurement end.

(4) After a measurement end, if CLEAR button is pushed, a display will be cleared by zero. When continuing measurement, it repeats from (1) again.

(5) Choose the TRACK mode, if real time torque value want to be measured

**5. Power supply**

If this measuring instrument is left 10 minutes or more or battery capacity stops being sufficient, a power supply is turned off automatically. If battery capacity decreases, since LOBAT will be displayed, charge by inserting the connector of an exclusive charger in an AC ADAPTOR terminal.

The fully charge is in the state which turned OFF the power supply switch, and takes about 8 hours.(Do not perform charge of 8 hours or more. It may become the cause of the fire by a burst of a battery, generation of heat, and liquid leak, or an injury by fault charge.)

Moreover, when turning off a power supply, a power supply SW is pushed for about 1 second.

**6. Date transfer (PEAK Mode Only)**

6.1 Date format

Data transfer is RS-232C output conformity. Data can be outputted to the printer corresponding to RS-232C, or a personal computer etc.

Spec.	Data bit length	Start bit 1 + data bit 8 + stop bit 2 + NO parity
	Baud rate	9600bps
	Connector form	D-Sub-9pin
	Connector spec.	No. 3 pin : Data output / No. 5 pin : GND

[18]	○○○	[OE]	[20]	+/-	○○○○○	[20]	[OF]	○○○○○○	[OD]
				Measured					CR
CAN	※	SO	Space	Mark	value	Space	SI	Unit	
All data 21									

- CAN : Cancellation
- ※ : Case in the memory mode Number of samples · Usually case in the mode Space
- SO : Double width expansion printing specification
- +/- : Measurement mark + the direction of bolting · - return direction
- Measured value : A decimal point is also included.  
The last is a space when there is no decimal point.  
[1][0][.][0][0] → 10.00 SI.
- SI : Double width expansion printing release
- Unit : In the case of N·m etc., the remainder space  
[N][·][m][ ][ ][ ] → N·m ( [k][g][f][·][c][m] → kgf·cm )
- CR : Carriage return
- △cautions An interface cable is used for connection of a computer.  
Unite with a computer and prepare a cable.  
Please inquire about a cable of a dealer where you purchased the product.

6.2 Output method of data

Data is outputted whenever it pushes CLEAR key after a measurement end.  
Date output of the time of use of an date clear function is automatically carried out in setting time.

**7. Guarantee**

It is allowed to fix gratuitously, if the fault which will originate in manufacture, ransportation, etc. of our company within one year after a purchase should occur, although product was manufactured under sufficient quality control.

In the following case, it becomes the charge also within a guarantee term.

- Failure by the error, and unjust repair and unjust reconstruction and damage on use
- Failure by fall etc. and damage after a purchase
- Failure by the natural disaster, pollution, and unusual voltage, and damage

***8. Calibration trust service***

---

Periodical calibration is required in order to manage the accuracy of torque meter. By our company, the calibration with the high reliability traced to the national standard is performed, and in order to use it within accuracy, I recommend you calibration of one year. I offer an result of calibration document, a certification on calibration, and a traceability system figure by demand. (Periodical calibration is a charge.)

Documents appended at the time of product purchase

- Result of calibration document
- Certification on calibration document
- Traceability system figure

**The cautions on use**

- \* Please do not apply the load more than the measurement range by any means.
- \* Attached grease is attached to the bolt or the bearing part, please check before use.
- \* Where a spring is loosened, please be sure to keep after use.

The number of times of an exchange standard is about 2500 times.

When the following condition comes out, please stop use, and use new joint.

- When there is bend and wear of a screw thread
- When there is sound etc.

**For any inquiry, please contact your dealer !**

---